

Operating Instructions K30 Single Espresso Grinder

„Grind-on-Demand“

K30 ES
K30 Vario



The professional art of grinding
since 1924



Dear customer / service personnel

the "Single Espresso Grinder K30" is a fully automatic espresso coffee grinder of the proven MAHLKÖNIG quality.

We have developed this product with over 80 years of experience in the manufacture of coffee grinders assuring you of high quality grinding of espresso and other types of coffee beans.

Read through and observe the operating instructions, so you and your customers will thoroughly enjoy the "K30". Please store the instructions in a safe place. If anything is unclear or additional information is required, please contact your authorized dealer or us as the manufacturer. We will be pleased to advise you further. We wish you unlimited pleasure and success with our product.

MAHLKÖNIG GmbH & Co. KG

Table of Contents

1. Safety	4	8. Cleaning	12
1.1 Symbols	4	8.1 Cleaning with GRINDZ™ grinder cleaner	12
1.2 Safety instructions	4	8.2 Cleaning the grinder placement surface	13
1.3 Usage purpose	5	8.3 Cleaning the grinder casing	13
1.4 User requirements	5	8.4 Cleaning of the hopper	13
2. Technical Data	5	9. Service	13
3. Description	6	9.1 Exchange of the built-in grinder EK11	13
4. Safety Devices of the Grinder	7	9.2 Grinding disc exchange	15
5. Set-Up and Basic Adjustment	7	9.3 Recalibration of the grind adjustment	16
5.1 Usage location	8	10. Spare Parts	16
5.2 Mounting the hopper	8	11. Wiring Diagrams	17
5.3 Electrical installation	8	12. Certificate	19
5.4 Adjustment of the port-a-filter rest	8	13. Warranty Conditions	19
6. Operation	8		
6.1 Handling the Grinder	8		
6.2 Grind adjustment (grinding fineness)	9		
6.3 Software menu	10		
7. Operating faults	11		

1. Safety



Please carefully read and observe the following safety instructions. Failure to do so can result in damage to the grinder and danger to the user.

1.1 Symbols

The following two symbols are used in these operating instructions:



Safety Instruction:

Imminent accident danger if you fail to observe.



General Instruction:

Failure to observe can result in damage to the grinder and optimum operation cannot be guaranteed.

1.2 Safety instructions

Only whole roasted coffee beans may be ground in the K30 ES / K30 Vario.

When unpacking please inspect whether the power supply (voltage) complies with the grinder voltage on the manufacturer's name plate on the bottom of the grinder. Never operate the grinder in damp or wet surroundings.

Always remove the electrical plug from the outlet prior to conducting maintenance or cleaning work on the grinder. Also, prior to removing the hopper, the plug must be removed from the electrical outlet.

Never operate a grinder with a damaged electrical cord. Inspect the grinder regularly for damages of the electrical cord, plug, etc.

Any required repairs may only be conducted by authorized service personnel. For this reason, please contact a customer service repair facility, your dealer or us directly as the manufacturer.

Do not exceed the maximum allowable continuous grinding time of 20 min. Afterwards, allow the grinder to cool off before the next operation.

Do not make any modifications or alterations to the grinder. The manufacturer assumes **absolutely no liability** for damages occurring from failure to observe these instructions.

Children cannot appreciate the dangers that can exist in the operation of electrical grinders. For this reason, never leave children unsupervised with electronic appliances such as this grinder.



Never submerge the grinder in water and never operate with wet hands.

1.3 Usage purpose

Only whole, unground, roasted, cleaned coffee beans may be ground in the K30 ES / K30 Vario grinder. Never use the grinder to grind other products or objects.

1.4 Personnel requirements

No special requirements are necessary for the users of this grinder. Nevertheless it is a prerequisite that these operating instructions have been carefully read and understood and that all instructions provided are observed. In addition, safety-conscious operation is expected.

2. Technical Data

Type	K30 ES, K30 Vario
Voltage/Frequency	200-230V / 50/60Hz 240V / 50Hz 100-115V / 50/60Hz
Rotation	
@ 50Hz	1420 rpm
@ 60 Hz	1640 rpm
Sound Emission	
Idle Operation	55 dB
Operation	75 dB
Pre-Fuse	16 A-slow
Overload Circuit Breaker	
230-240V	4A T (slow)
110-115V	7A T (slow)
Max. Permissible Running Time of the Grinder	S320%eg(4sec.on/16sec.off) (6 sec. on; 60 sec. off)*
Dimensions in mm	W 240, D 320, H550
Weight	13 kg (28.7 lbs)
Hopper Capacity	1,5 kg (3.3 lbs.)

(Please request technical data for other voltages and frequencies from the manufacturer or dealer.)

* only for 115V 60Hz

3. Description

The main components and operating elements are pictured in the illustration.

- Pos. 1 Hopper with lid
- Pos. 2 Lock screw for hopper
- Pos. 3 Grinding fineness adjustment*
- Pos. 4 Lock screw for grind adjustment lid
- Pos. 5 Grind adjustment lid
- Pos. 6 Grinding fineness scale
- Pos. 7 Display
- Pos. 8 Single shot pre-selection button
- Pos. 9 Single shot timer
- Pos. 10 Double shot pre-selection button
- Pos. 11 Double shot timer
- Pos. 12 Spout
- Pos. 13 Port-a-filter mounting
- Pos. 14 Port-a-filter rest
- Pos. 15 Fastening screw for Port-a-filter rest
- Pos. 16 Start / Stop switch
- Pos. 17 Drip tray
- Pos. 18 Hopper slide
- Pos. 19 Main switch (back)
- Pos. 20 Trip switch (back)
- Pos. 21 Power cable (back)



* for Vario with adjustment screw on the lid

4. Safety Devices of the Grinder

Thermal overload circuit breaker

The motor of the grinder is protected by a thermal overload circuit breaker, which interrupts the motor's electric circuit in the event of electric overload. The trip switch, item 20, must be pressed to enable the grinder to be re-started.

Motor protector

The winding of the motor is protected by a thermal switch (thermo pill/bimetal), which will trip when the motor heats up significantly. The grinder cannot be started again. Let it rest for approx. 30 minutes. The thermal switch will re-connect the motor automatically.



The user has no influence whatsoever on these circuit breakers. If the circuit breaker trips repeatedly, an authorised service partner must be consulted, as the motor's winding may be damaged.

Micro-switch at the grinder's lid

The grinder's lid is secured by a micro-switch, which will block the motor in case the lid is open. The grinder can only be started with the lid closed. (see chapter 7)

5. Set-up and Basic Adjustment

A grinding test run is carried out on each grinder in our factory. This is why you may find ground material residue in the grinding mechanism!

You have received your grinder in operating condition. Now you only need to mount the hopper and connect the grinder to the mains plug. Proceed as follows

5.1 Usage Location

Place the grinder on a level, vibration-free surface.



Never operate the grinder in moist, or even worse, in wet surroundings!

5.2 Mounting the hopper

5.2.1 Position the hopper (pos.1) in the bayonet in the grinder's lid. Note: The hole in the hopper-adapter has to line up with the safety screw (pos. 2) in the lid.

5.2.2 To lock the hopper grab the hopper with both hands and turn it clock-wise until it clicks in.

5.2.3 Secure the hopper with the safety screw (pos.2). Use the provided long allen wrench (2mm).

5.2.4 Open the hopper slider (pos. 18) in the adapter.

5.3 Electrical installation



Protect your device with separate pre-fuses (not included in the scope of delivery) according to the information provided under Point 2 “Technical data”.



Make sure that the pre-fuse is not overloaded by other devices (e.g. fan heaters, deep freezers).



Check whether the main voltage and frequency correspond to the information on the rating plate.

Insert the plug into the corresponding grounded outlet.

5.4 Adjustment of the port-a-filter rest

The grinder is designed so that all different port-a-filters from various espresso machines fit into the rest (pos.14) for hands-free grinding operation.

Proceed as follows for adjusting the port-a-filter rest:

5.3.1 Keep the grinder switched off. Slightly loosen the allen screws (pos. 15) with the provided allen wrench size 3mm and pull down the port-a-filter rest (pos. 14).



In case the port-a-filter rests do not fit your espresso machine’s port-a-filter, please contact us or your local dealer. We will be happy to send you a different rest.

5.3.2 Push the port-a-filter of your espresso machine onto the start/stop switch between the port-a-filter mounting and the rest.

5.3.4 Now push up the port-a-filter rest until the port-a-filter holds on its own. Refasten the screws.

6. Operation

Only use the K30 ES / K30 Vario espresso grinder for whole roasted coffee beans. See chapter 1.3.



Observe the safety instructions under 1.2!

The max. permissible operating cycle for 200-230V and 240V is 4 sec. ON and 16 sec. OFF, i.e. three double shots per minute. For 115V the max. permissible operating cycle is 6 sec. ON and 60 sec. OFF. Do not exceed the maximum allowable continuous grinding time of 20 min. Afterwards, allow the grinder to cool down before the next operation.

6.1 Handling the grinder

Proper operation necessitates the steps described in the following:

6.1.1 Actuate the main switch on the rear of the grinder (pos. 19).

6.1.2 Open the hopper. Pour whole roasted espresso beans into the hopper from above. **Never pour in coffee powder.** Close the hopper.

6.1.3 Check whether the hopper slide (pos.18) is open.

6.1.4 Choose the pre-selection button for a single or double shot of espresso (pos. 8+10).

6.1.5 Push the port-a-filter of your espresso machine into the rest. Grinding starts and ends automatically.

6.1.6 Break function: If you pull out the port-a-filter while grinding the process will be interrupted. The LED of the active pre-selection button blinks. The process can be continued by pushing the port-a-filter back onto the start-button. The saved, missing amount will be ground.

For stopping the grinder and deleting the remaining time simply push the blinking pre-selection button. The entire set grinding quantity or grinding time is available once again.

6.2 Grind adjustment (grinding fineness)

Adjust the grinding fineness by pulling the sliding detent out to the front* and turning the lid / grinding fineness adjustment to the mark 2.

Note that “0” is the finest setting and “10” is the coarsest setting.

*respectively for K30 Vario: loosen the adjustment screw and refasten it after the adjustment

Rotation to the left = fine
Rotation to the right = coarse



6.3 Software menu

Display



To enter the menu:

Press and hold for 3 sec:



Press:



Adjust double shot time

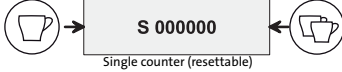

Single counter (resettable)



Double counter (resettable)



Single counter continuous



Double counter continuous



BACK

CONTINUE

Press and hold for 3 sec:



Save the changes

6.3.1 Adjust the grinding time (dosing)

- Simultaneously press and hold both buttons (pos. 8+10) for appr. 3 seconds. The display reads MENU.
- Let go the buttons, the display reads STI (single time). Use the left potentiometer (pos. 9) to adjust the grinding time for a single espresso (rule of thumb 1,5 – 2,7 seconds).
- Scroll down with the single pre-selection button (pos.8) to DTI (double time). Use the right potentiometer (pos. 11) to adjust the grinding time for a double espresso (rule of thumb 2,5 – 4,5 sec).
- After the adjustment of any setting press and hold both buttons again to save the changes. The display reads SAVE.

6.3.2 Shot counters (daily counter and overall counter)

- Enter the menu by pushing and holding both buttons for appr. 3 seconds.
- Scroll through the menu with the single pre-selection button (pos. 8) until the display reads S. The figure shows the number of single shots that were ground since the last reset.
- Scroll down with the single button to the display reading D. The figure shows the number down double shots that were ground since the last reset.

- Scroll down with the single button to the display reading SC. The figure shows the total number of single shots that were ground on this grinder. (not resettable)
- Scroll down with the single button to the display reading DC. The figure shows the total number of double shots that were ground on this grinder. (not resettable)

For exiting the menu press and hold both buttons for appr. 3 seconds.

6.3.3 Resetting the daily counter

- Switch off the grinder (pos. 19).
- Press and hold both buttons and switch back on the grinder.
- Hold both buttons until the display reads RESET. The daily counters are set back to Zero.

7. Operating faults

Defect	Cause	Remedy
The grinder hums but does not grind.	The spout is clogged.	Set grinding fineness to “coarse” and trigger the grinding process. The grinder will then grind itself free. Afterwards, return the setting to the desired grinding fineness.
	Grinding is set too fine.	Turn the grinding fineness setting to the right, to “coarse”, and trigger the grinding process. The grinder will then grind itself free. Afterwards, return the setting to the desired grinding fineness.
	A foreign object is in the grinding mechanism.	Clean the grinding mechanism as described and remove the foreign object. Observe the safety instructions!
The grinder does not grind, the display is lit, single cup is pre-selected	The grinding time is set to 0.	Reset the grinding time.

Defect	Cause	Remedy
The grinder does not start, the display is not lit.	The main plug is not inserted.	Insert the main plug into the socket.
	The overload circuit breaker has been tripped.	Check to determine whether the trip button of the circuit breaker has jumped out. Press the trip button in again if appropriate. If the circuit breaker trips repeatedly, contact your authorised customer service centre or dealer.
	The pre-fuse has tripped.	Check the pre-fuse. Restore the pre-fuse to its initial state or replace it. Determine whether other devices are connected to this fuse.

In the case of other malfunctions or continued faults, please contact your dealer or your authorised customer service centre.

8. Cleaning

You should clean your espresso grinder regularly, just like your espresso machine. Grind-on-demand grinders in particular have to be kept clean and residue free in order to ensure dosing accuracy for every shot and every customer.

8.1 Cleaning with GRINDZ™ grinder cleaner

We recommend cleaning your espresso grinder once every 1-2 weeks (every 25 kg) with our GRINDZ™ Grinder Cleaner.

For cleaning your grinder with GRINDZ™, just follow the steps below:

- Close the hopper slider and grind the remaining coffee out of the grinder casing.
- Take off the hopper.
- Fill 35 grams of GRINDZ™ directly into the grinder casing (content of one sachet or one can's lid).
- Reposition the hopper on the grinder.
- Adjust the fineness to coarse (for a better cleaning effect of the GRINDZ™-particles).
- Start the grinder and grind through all GRINDZ™ into your port-a-filter or a separate bin (several shots needed).
- Open the hopper slider and grind appr. 2 - 3 double shots of coffee in order to purge the residues of GRINDZ™ out of the disc casing.



Formation of dust while grinding GRINDZ is natural and harmless. The dust particles can be cleaned with a soft cloth from the aroma fez and the spout.

8.2 Cleaning the grinder placement surface



Pull out the mains plug!

- Lift the grinder aside and clean the area on which it stands and the bottom of its base.
- Both surfaces must be dry and free of oil and grease.
- Reposition the grinder

8.3 Cleaning the grinder casing

From time to time clean the outside of the casing and the drip tray (pos.17) using a damp cloth.

8.4 Cleaning of the hopper

The hopper should be cleaned daily with a damp cloth inside and outside in order to remove coffee and oil residues which could negatively influence the taste in the cup.



Do not clean the drip tray or the hopper in the dish-washer. Its colour might fade.

9. Service



Always pull out the main plug from the socket before carrying out maintenance or cleaning work on the grinder!



Do not let any foreign objects fall into the grinding mechanism!



Inspect the grinder regularly for damage, particularly to the electrical cable, plug, etc.



Any required repairs may only be conducted by authorized specialist personnel. For this reason, please contact a customer service repair facility, your dealer or us directly as the manufacturer. Observe the safety instructions under 1.2!

9.1 Exchange of the built-in grinder EK11

In case of a defect in the built-in grinder it can easily be exchanged in one piece. Service hours can be minimised and the grinder is quickly ready for operation.

9.1.1 Close the hopper slide, grind all remaining coffee beans out of the discs, loosen the safety screw (pos.2) and take off the hopper.

9.1.2 Switch off the grinder and pull the mains plug. Place the grinder on its side and unscrew the fastening screws. Store the screws and washers in a safe place. Re-position the grinder on its rubber feet.

9.1.3 Remove the lid's safety screw (pos. 4) and turn the lid to the coarsest setting. Lift off the lid from the grinder.

9.1.4 Release the motor's plug-in connector. Carefully pull the integrated grinder out of the casing.

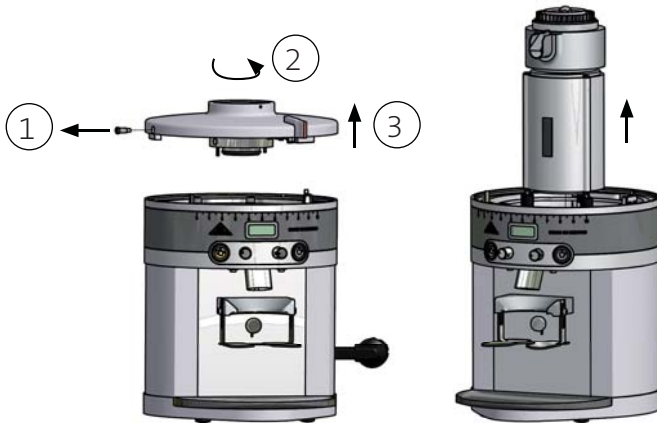

9.1.5 Carefully vacuum out the grinder casing and the integrated grinder's spout and clean with a brush. **Do not damage any cables!**

9.1.6 Insert the new built-in grinder into the casing.



Check for the correct position of the flat spring in the built-in grinder's spout. It has to extend into the spout instead of laying on top of the spout tube.

9.1.7 Connect the motor plug with the grinder and store the connection well in the rear of the casing.

9.1.8 The cover of the built-in grinder is marked with two red lines:

Red Mark 1: Basic adjustment 0, finest setting and minimum grinding disc spacing.

Red Mark 2: Basic factory setting and also the position for installing and removing the lid, in order to achieve the factory setting after positioning the lid.

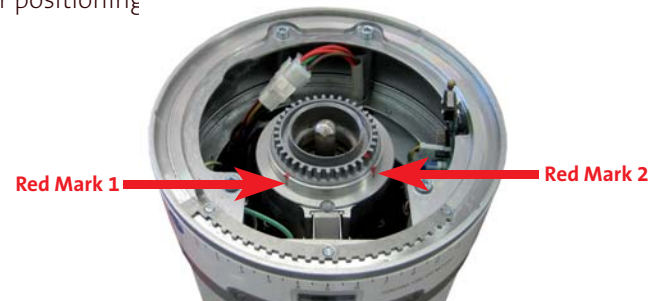

Therefore turn the grind adjustment of the built-in grinder to the right red mark 2 for refitting the grinder's lid.

9.1.9 Replace the grinder's lid on the grinder and adjust to the desired fineness.



Note the correct position when lowering the lid onto the grinder. The detent screws have to fit into the gaps. Otherwise the basic adjustment is lost and espresso grinding is not possible anymore.

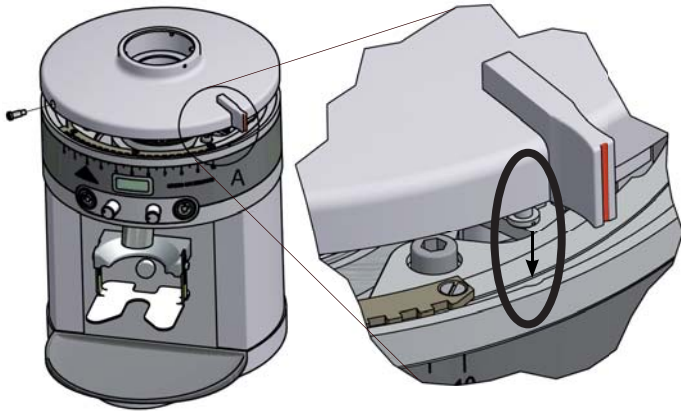

9.1.10 Carefully lay the grinder on its side. Reassemble the three screws under the base plate. Reposition the grinder on its rubber feet.

9.1.11. Replace the hopper in the bayonet, fasten the safety screw and open the hopper slider.

9.2 Grinding disc exchange

The grinding discs should be exchanged if any of the following symptoms emerge:

- loss of grind capacity (>5sec for a double shot of espresso of 15g)
- significant heating of the ground coffee
- uneven particle size distribution
- change of the sound of the grinder (due to the change from cutting to grating).

Grinding disc replacement should only be carried out by authorised specialists or a customer service centre. "Repair manual K30 grinding disc replacement and basic adjustment", article No. 6592, is recommended for replacing grinding discs.

Grinding disc replacement may also be carried out using a replacement built-in grinder. To do this, order a built-in grinder. On receipt of the built-in grinder, remove your grinder from the K30 ES / K30 Vario according to chapter 9.1 and install the new built-in-grinder into your K30. Return your old built-in grinder in the packaging.

9.3 Recalibration of the grind adjustment

Due to wear and tear of the grinding discs or after exchanging them the Zero-grind-adjustment has to be recalibrated.

- Turn the grind adjustment to the finest setting “0”.
- Close and remove the hopper.
- Remove the remaining beans from the filler shaft and vacuum out the grinder casing.
- Remove the silicone sealing ring from the filler shaft.
- Loosen – do not unscrew – the adjusting screws with the included Allen key (size 2.5, article No. 6568 - also available in service-kit).
- Insert the adjusting handle (service-pack) into the filler shaft. The adjusting handle must engage in the slot in the filler shaft’s transverse bar.
- Start the grinder.
- Whilst the grinder is running, turn the adjusting handle clockwise until a slight ringing sound becomes audible. Now turn the adjusting handle back anti-clockwise until no further ringing sound can be heard.



It is important to ensure that no grinding disk “rattling” can be heard at the finest setting! Otherwise the service life of the discs will be significantly reduced!

- Tighten the adjusting screws and remove the adjusting handle from the filler shaft.

- Insert the sealing ring again. If the sealing ring is damaged, it must be replaced.
- Refit the hopper and fasten the safety screw. Open the hopper slide.

10. Spare Parts

Spare parts are usually ordered from your customer service centre or your local dealer. To ensure quick and correct processing of your order, the following information is absolutely essential:

1. Type designation, serial number and voltage of the grinder (on the rating plate underneath the grinder).
2. An exact description of the part to be replaced or the article number.

11. Wiring Diagram 100-115V 50/60Hz

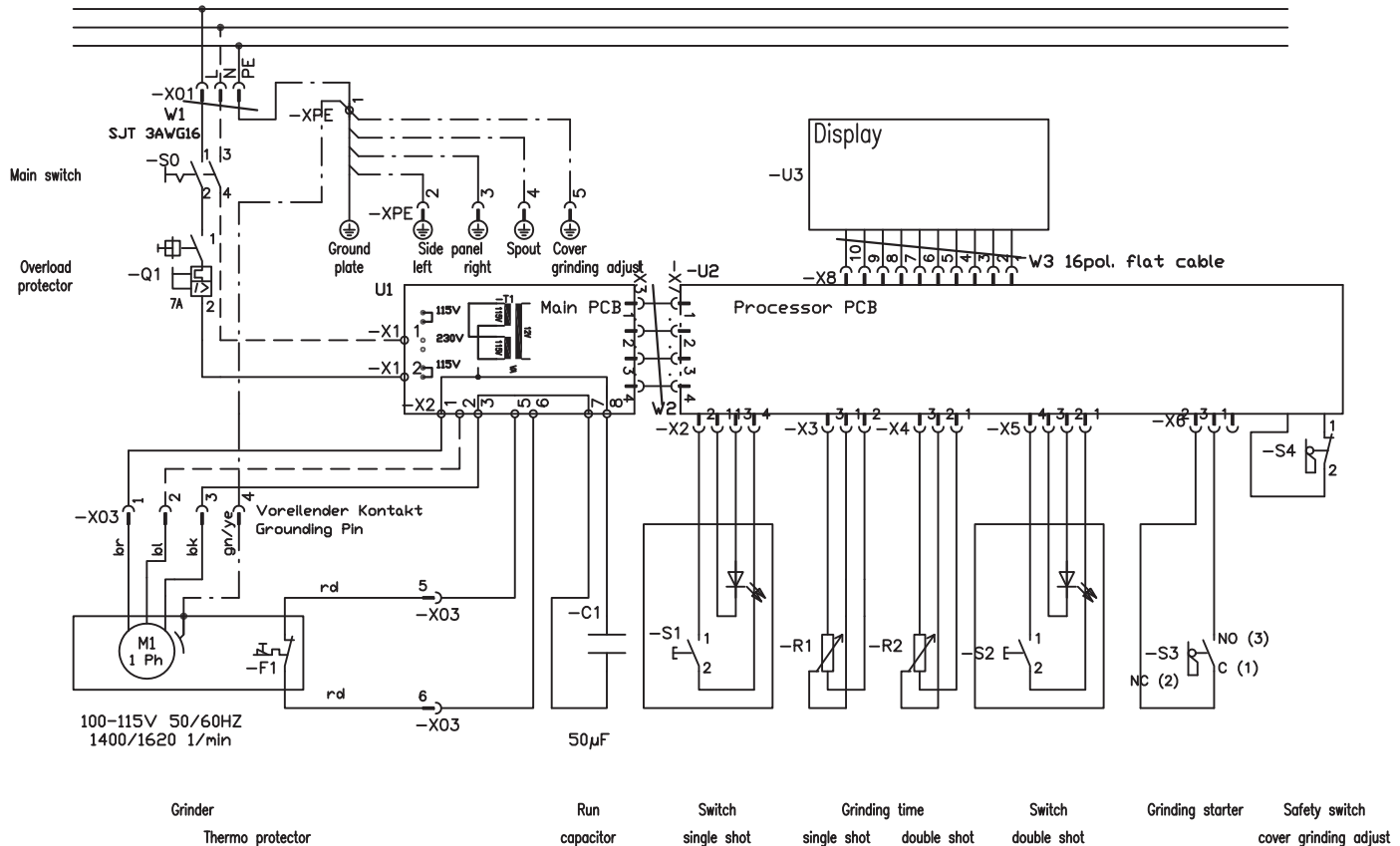

Wiring Diagram 200-230V 50/60Hz, 240V/50Hz

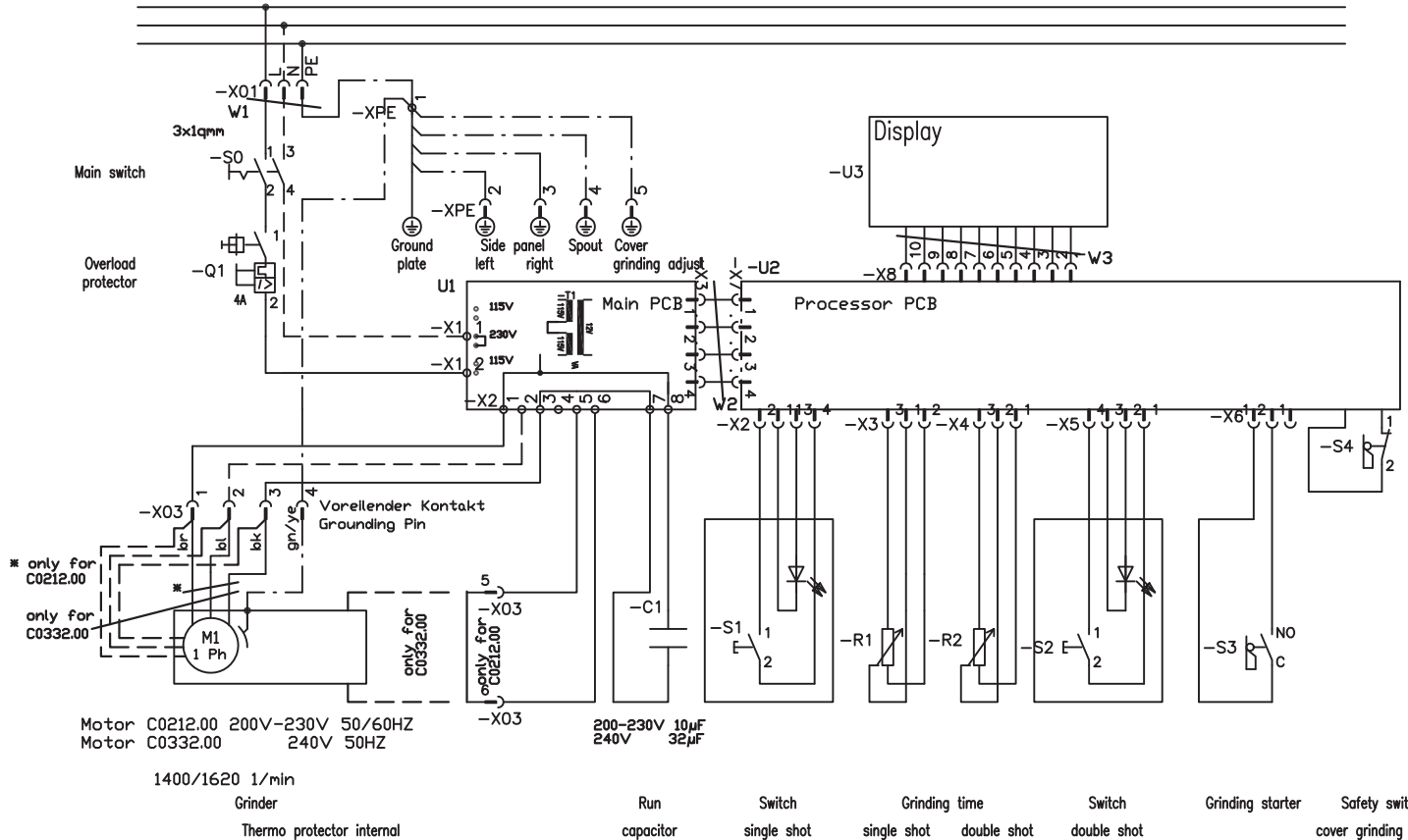

12. Certificate

<p>EC Declaration Conformity As defined by EMC-directive 89/392/EWG</p>		 <p>MAHLKÖNIG GmbH & Co. KG Tilkestr. 31/32/11-141, 20049 Hamburg Telefon: +49 40 - 69 69 40 - 0 Telefax: +49 40 - 69 99 771</p>
<p>Name of the manufacturer or in the EU residential authorized person:</p>		
<p>HEMRO AG</p>		
<p>Address of the manufacturer or the authorized person:</p>		
<p>Bramenstrasse 11, CH-8184 Bachenbülach</p>		
<p>announce, that the machine below</p>		
product type:	commercial device for food processing	
machine description:	Coffee grinder	
machine typ:	K30 ES, K30 Vario	
<p>is in compliance with the conditions of the Directive of Machines 98/37/EG and with the main standards stipulated in the Directive concerning low tension 73/23/EWG and applies to the national laws that transpose it.</p>		
Issued in Bachenbülach:	01.01.2008	
Function of subscriber:	Managing Director	
Name of subscriber:	Nils Erichsen	
<p>Signature</p> 		
<p><small>MAHLKÖNIG GmbH & Co. KG, Amtsgericht Hamburg HR A 85 074; Persönlich haftende Gesellschafterin: Beteiligungsgesellschaft MAHLKÖNIG mbH, Eintragsamt Amtsgericht Hamburg HR B 45 324, Geschäftsführer: Nils Erichsen Dresdener Bank AG (BLZ 200 800 00) Kto. 393 790 400; Postbank Hamburg (BLZ 200 100 20) Kto. 253 99 - 003 Commerzbank AG (BLZ 200 400 00) Kto. 21 10 294, Ust. Id. Nr.: DE 118 37 22 65</small></p>		

13. Warranty Conditions

- The warranty period is 1 year from the date of purchase.
- The warranty covers all damages that can be attributed to inferior materials or defective workmanship. Corresponding grinders will be repaired or replaced free-of-charge, with the exception of transport or freight charges. Transport is the responsibility of the customer. Therefore, avoid damages with all returns by correct packing.
- The grinder may only be opened for cleaning purposes in accordance with the Operating Instructions.
- This warranty does not cover damages which have occurred through: Improper usage, improper maintenance, lack of servicing, usage for purposes other than those intended, incorrect installation, incorrect voltage, breakage, natural wear or for reasons beyond our sphere of influence.
- In order to maintain the warranty, only original spare parts and accessory parts may be used.
- Observe in addition our General Delivery Conditions in their respective current version.
- The manufacturer is in no way liable for consecutive or secondary damages.
- The warranty does not cover costs resulting from repairs conducted by non-authorized personnel.

MAHLKÖNIG GmbH & Co. KG

Tilsiter Straße 142
D- 22047 Hamburg, Germany

Phone: +49 (0)40 / 69 69 40-0

Fax: +49 (0)40 / 69 39 721

office@mahlkoenig.de ; www.mahlkoenig.de

November 2009

Subject to change without prior notice!!



The professional art of grinding
since 1924